

Adnaco Technology Inc.
System connectivity beyond imagination

2nd Floor, 5050 Kingsway
Burnaby, BC V5H 4H2, Canada
Tel: +1.604.639.5981, Fax: +1.604.909.4716
E-mail: info@adnaco.com
<http://www.adnaco.com>

Adnaco PCI Express Over Fiber Optic Systems

User's Guide

Contents

User's Guide.....	1
1 Terminology	4
2 Read This First.....	5
3 System Overview	6
4 Items Description and Ordering Information.....	7
4.1 H1A host adapter	7
4.1.1 H1A drawing.....	7
4.1.2 DIP switch description	8
4.1.3 LEDs description.....	8
4.2 R1BP1A PCI/PCIe backplane	9
4.2.1 R1BP1A drawing.....	9
4.2.2 DIP switch description	10
4.2.3 LEDs description.....	10
4.2.4 Connectors and jumpers description	11
4.3 R1BP1B PCIe backplane	14
4.3.1 R1BP1B drawing.....	14
4.3.2 DIP switch description	15
4.3.3 LEDs description.....	15
4.3.4 Connectors and jumpers description	16
4.4 Optical transceivers and fiber optic cable	17
4.5 ATX I/O shield	18
4.6 Adnaco-S1A system	19
4.6.1 Block diagram	19
4.7 Adnaco-S1B system.....	20
4.7.1 Block diagram	20
4.8 Adnaco-S2A system	21
4.9 Adnaco-S2B system.....	21
4.10 Ordering and pricing information	21
5 Installing Adnaco-R1BP1x in ATX chassis.....	22
5.1 Connectors schematic	22
5.2 Power supply minimum load.....	22
5.3 Installing R1BP1x	22
6 Using R1BP1x with Custom Power Supply	24
6.1 Custom power supply requirements	24

6.2	Power cable	25
6.3	R1BP1x configuration	27
6.4	Connecting power supply to R1BP1x.....	27
7	System Operation.....	29
7.1	R1BP1x Power On/Off Modes	29
7.2	Manual Power-On/Off Sequence (modes 1 and 2)	29
7.3	Automatic Power-On/Off Sequence (mode 3)	29
8	System Installation.....	30
8.1	Installation recommendations.....	30
8.2	Installing Adnaco-H1A PCIe Host Adapter Card.....	30
8.3	Installing Third-Party PCI or PCIe Cards in the Adnaco-R1BP1x backplane	30
8.4	Connecting the Fiber Optic Cable	30
8.5	Turning on system for the first time	31
9	Verifying System Functionality.....	32
10	Troubleshooting	36
10.1	The R1BP1x is not turning ON or its LEDs (other than link LEDs) are flashing	36
10.2	Your host computer BIOS is not up-to-date.....	36
10.3	The H1A is not visible in the Device Manager.....	36
10.4	The host computer hangs during power on.....	36
10.5	Fiber optic cable and transceivers verification	37
10.6	The R1BP1x is not visible in the Device Manager.....	37
10.7	Third-party add-in cards installation problem	37
10.7.1	Add-in card requires auxiliary voltage to operate	37
10.7.2	PCIe add-in card problems.....	37
10.7.3	Interoperability issues with some PCIe Gen 1 cards.....	38
10.7.4	PCI add-in card problems	38
11	Adnaco Products Design Disclaimer.....	39
12	Customer Support.....	40
13	Warranty	41
14	Appendix A Board drawings with dimensions.....	42

1 Terminology

Table 1-1 Common terms used in the user's guide

Term	Description
Add-in card	A card that is plugged into a connector and mounted in a chassis
ATX	A system board form factor. Refer to the ATX Specification
xN	xN refers to N PCI Express Lanes
EMI	Electromagnetic Interference
ESD	Electrostatic Discharge
GT/s	Gigatransfers per second
Gen1	PCIe 2.5 GT/s
Gen2	PCIe 5 GT/s, backward compatible with Gen1
H1A	Adnaco-H1A host adapter
Link	A collection of one or more PCI Express lanes
microATX	A system board form factor. Refer to the microATX Specification
OS	Operating system
PCI	Interconnect standard for PCI cards
PCIe	Interconnect standard for PCI Express cards
R1BP1A	Adnaco-R1BP1A PCI/PCIe backplane
R1BP1B	Adnaco-R1BP1B PCIe backplane
R1BP1x	R1BP1A or R1BP1B backplane
S1A	Adnaco-S1A system
S1B	Adnaco-S1A system
S1x	S1A or S1B system
S2A	Adnaco-S2A system
S2B	Adnaco-S2B system
S2x	S2A or S2B system
SFP	Small Form-Factor Pluggable Transceiver
RMA	Return Material Authorization

2 Read This First

SAFETY INSTRUCTIONS

The precautions noted within this User's Guide are intended to instruct you in the safe and correct use of the system in order to prevent bodily injuries and equipment failure. Please read and ensure that you understand them before proceeding to other sections of the guide.



Warning This symbol indicates topics that could lead to equipment malfunctioning if ignored or handled incorrectly.

3 System Overview

Adnaco S1x and S2x are PCI Express Gen 2 systems based on Adnaco PCI Express over fiber optic technology. The PCI Express Gen 2 systems offer twice the bandwidth of Gen 1 at lower cost. The systems can operate with single-mode or multi-mode cable and transceivers which allow the system to use a cable up to a few hundred meters with a temperature range from -40° C to +85° C.

The Adnaco Expansion Systems allow system integrators to operate PCI and PCIe add-in cards over fiber optic cable at long distances from the location of the computer system. No additional host software drivers are required during installation or operation. Any type of PCI and PCI Express cards can be used including audio, video, graphics, USB, FireWire, SATA, data-acquisition, network and others.

Each system consists of a host adapter, a remote backplane and a fiber optic cable. The Adnaco-H1A PCIe 5GT/s Gen 2 host adapter card provides an interface between a host computer PCIe bus and a fiber optic cable. The R1BP1A backplane has 2 PCI slots and 2 PCIe x16 slots. It is intended for applications where customers need to operate legacy PCI add-in cards along with PCI Express Gen 2 and Gen 1 cards. The R1BP1B backplane has four PCIe Gen 2 x16 slots backward compatible with Gen 1. Both backplanes can operate in temperature range from -20° C to +85° C or -40° C to +85° C depending on optical transceiver.

The optical isolation and long cable allows the system integrator to use the system in applications where equipment has to be isolated from the computer or operate under harsh environmental conditions. The unique feature of the Adnaco PCI Express over fiber optic technology is its transparent access to remote devices without compromising performance over long cables. The Adnaco expansion system is transparent to software applications and drivers, so industry standard desktop computers and servers can communicate with remote devices with no additional programming.

4 Items Description and Ordering Information

4.1 H1A host adapter

[Click here to download latest H1A datasheet](#)

4.1.1 H1A drawing

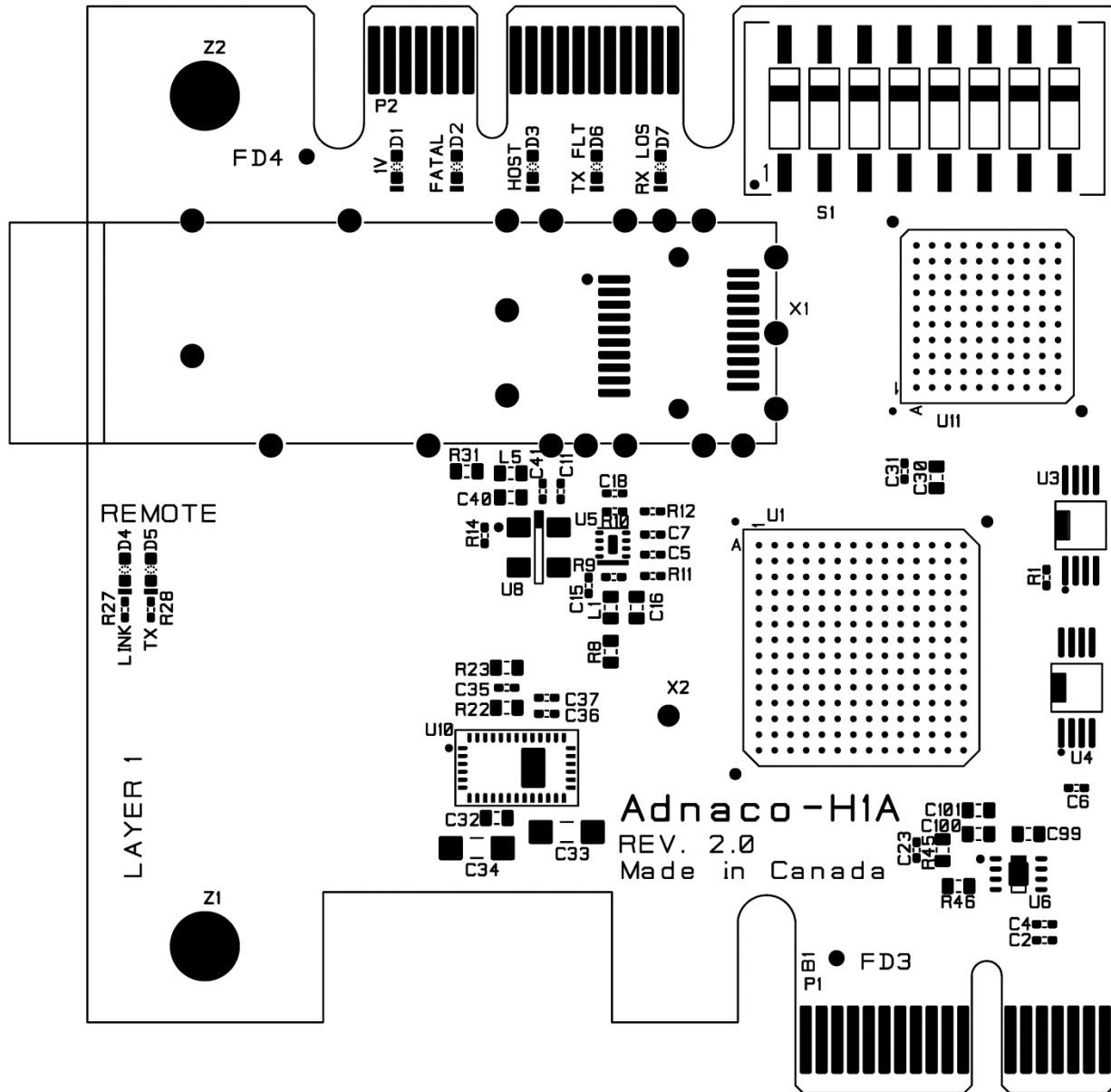

4.1.2 DIP switch description

Table 4-1 H1A DIP Switch

Switch	Description	Default
1-2	EEPROM selection 1 2 OFF OFF – EEPROM0: Gen2 at 5 GT/s ON OFF – EEPROM1: Gen1 at 2.5 GT/s OFF ON – EEPROM2: Reserved ON ON – NO EEPROM	OFF
3	Operating frequency: OFF – default ON – H1 compatible	OFF
4	Reset from remote OFF – disabled ON – enabled	OFF
5	Reserved	OFF
6	Reserved	OFF
7	Reserved	OFF
8	Reserved	OFF

4.1.3 LEDs description

Table 4-2 H1A LEDs

Designator	Description
D1	1V power OK
D2	Fatal Error. When ON, fatal error is detected and a reset of the board may be required to return to reliable operation.
D3	Host PC Link Status: OFF – Link is not active ON – Link operates at 5.0 GT/s Blinking, 0.5 seconds ON, 0.5 seconds OFF – Link operates at 2.5 GT/s
D4	Remote Link Status: OFF – Link is not active ON – Link operates at 5.0 GT/s Blinking, 0.5 seconds ON, 0.5 seconds OFF – Link operates at 2.5 GT/s
D5	Remote Link Status. When ON, Link is not active
D6	Transmitter Fault Indication. When ON, indicates a laser fault of some kind.
D7	Loss of Signal. When ON, indicates the received optical power is below the worst-case receiver sensitivity

4.2 R1BP1A PCI/PCIe backplane

[Click here to download latest R1BP1A datasheet](#)

4.2.1 R1BP1A drawing

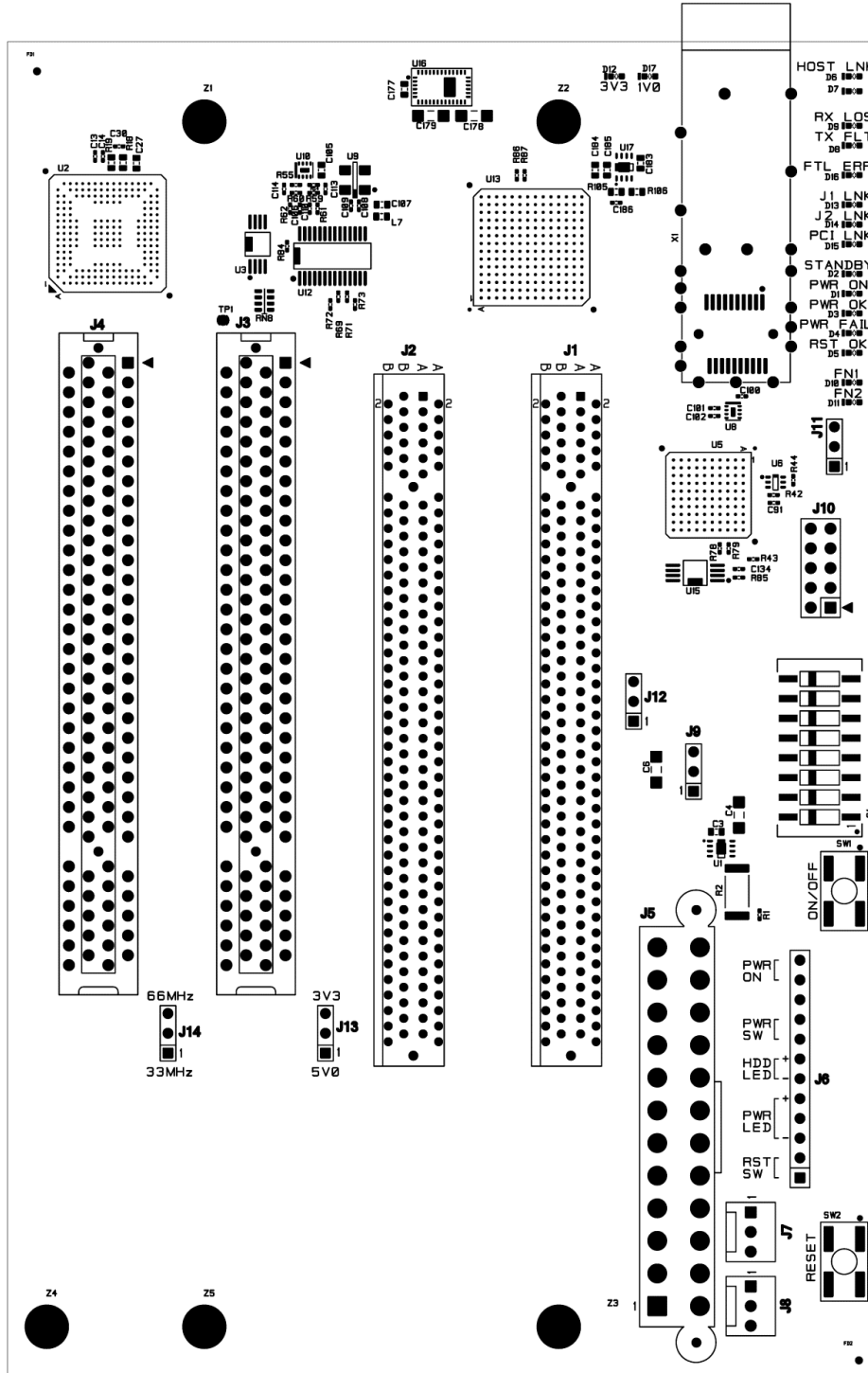

4.2.2 DIP switch description

Table 4-3 Adnaco-R1BP1A S1 DIP Switch

Switch	Description	Default
1-2	EEPROM selection 1 2 OFF OFF – EEPROM0: Gen2 at 5 GT/s ON OFF – EEPROM1: Gen1 at 2.5 GT/s OFF ON – NO EEPROM ON ON – NO EEPROM	OFF
3	Operating frequency: OFF – default ON – H1 compatible	OFF
4-5	Power control 4 5 OFF OFF – power ON/OFF controlled by SW1 button ON OFF – power is always ON OFF ON – power turned ON and OFF automatically when computer is turned ON and OFF	OFF
6	Reserved	OFF
7	Reserved	OFF
8	Reserved	OFF

4.2.3 LEDs description

Table 4-4 Adnaco-R1BP1A LEDs

Designator	Description
D1	Power ON – board is ON
D2	Stand-by – board is OFF
D3	Power OK – +3.3V, +5V, +12V are present
D4	Power failure – one (or more) of the +3.3V, +5V or +12V power supplies failed
D5	Reset OK
D6	Host adapter link status: OFF – Link is not active ON – Link operates at 5.0 GT/s Blinking, 0.5 seconds ON, 0.5 seconds OFF – Link operates at 2.5 GT/s
D7	Host adapter link failure. When ON, Link is not active
D8	Transmitter fault indication. When ON, indicates a laser fault of some kind.
D9	Loss of Signal. When ON, indicates the received optical power is below the worst-case receiver sensitivity
D10	Factory only
D11	Factory only
D12	3.3V power OK

Designator	Description
D13	J1 slot LED status Host adapter link status: OFF – Link is not active ON – Link operates at 5.0 GT/s Blinking, 0.5 seconds ON, 0.5 seconds OFF – Link operates at 2.5 GT/s
D14	J2 slot: Host adapter link status: OFF – Link is not active ON – Link operates at 5.0 GT/s Blinking, 0.5 seconds ON, 0.5 seconds OFF – Link operates at 2.5 GT/s
D15	PCI bridge link status: OFF – Link is not active Blinking, 0.5 seconds ON, 0.5 seconds OFF – Link operates at 2.5 GT/s
D16	Fatal Error. When ON, fatal error is detected and a reset of the board may be required to return to reliable operation
D17	1V power OK

4.2.4 Connectors and jumpers description

Table 4-5 Adnaco-R1BP1A Connectors

Designator	Description
J1	PCI Express x16 Add-in Card Connector (wired x1)
J2	PCI Express x16 Add-in Card Connector (wired x1)
J3	PCI Add-in Card Connector
J4	PCI Add-in Card Connector
J5	Main Power Connector (ATX24)
J6	Front Panel Header
J7	Chassis Fan Header
J8	Chassis Fan Header
J9	Standby 3.3V voltage 2-3 – default setting for a computer power supply. 1-2 – used for a custom power supply (there is no standby mode)
J10	Factory Only
J11	Not assembled
J12	+3.3Vaux source for PCI/PCIe slots Open – default, no +3.3Vaux voltage on the slots 1-2 – 3.3V main voltage from J5 connector 2-3 – 3.3V standby voltage from the local power supply (All add-in cards must consume less than 150 mA from +3.3Vaux power supply) Note: Although +3.3Vaux voltage is optional according to specifications some cards may not operate without it. It is left open by default

Designator	Description
J13	<p>PCI bus I/O voltage selection 1-2 – 5.0V (default) 2-3 – 3.3V</p> <p> Warning: Before setting to 3.3V I/O make sure that your card is designed to operate with 3.3V I/O voltage. Some consumer PCI cards incorrectly connect I/O pins to 5V internally and use a universal PCI connector which allows such cards to be installed into 3.3V PCI systems. This may result in damaging the PCI card, R1BP1A and power supply</p>
J14	<p>PCI bus frequency 1-2 – 33 MHz (default) Open – 33 MHz or 66 MHz depending on the slowest card installed.</p> <p>Note: According to the PCI specification a 66 MHz card should operate with 3.3V I/O voltage.</p>

Table 4-6 J5 Main Power Connector

Pin	Signal Name	Pin	Signal Name
1	+3.3VDC	13	+3.3VDC
2	+3.3VDC	14	-12VDC
3	GND	15	GND
4	+5VDC	16	PS_ON#
5	GND	17	GND
6	+5VDC	18	GND
7	GND	19	GND
8	PWR_OK	20	Not Connected
9	+5VSB	21	+5VDC
10	+12VDC	22	+5VDC
11	+12VDC	23	+5VDC
12	+3.3VDC	24	GND

Table 4-7 J6 Front Panel Header

Pin	Signal Name
1	Reset Switch
2	Reset Switch
3	Power LED (-)
4	Not Connected
5	Power LED (+)
6	Stand-by LED (-)
7	Stand-by LED (+)
8	Power Switch
9	Power Switch
10	Not Connected
11	GND

Pin	Signal Name
12	Power Supply ON (jumper on pins 11-12) Leave open and use S1 DIP switch to control power supply during normal operation

4.3.2 DIP switch description

Table 4-8 R1BP1B S1 DIP Switch

Switch	Description	Default
1-2	EEPROM selection 1 2 OFF OFF – EEPROM0: Gen2 data rate 5 GT/s ON OFF – EEPROM1: Gen1 data rate 2.5 GT/s OFF ON – NO EEPROM ON ON – NO EEPROM	OFF
3	Operating frequency: OFF – default ON – H1 compatible	OFF
4-5	Power control 4 5 OFF OFF – power ON/OFF controlled by SW1 button ON OFF – power is always ON OFF ON – power turned ON and OFF automatically when computer is turned ON and OFF	OFF
6	Reserved	OFF
7	Reserved	OFF
8	Reserved	OFF

4.3.3 LEDs description

Table 4-9 R1BP1B LEDs

Designator	Description
D1	Power ON – board is ON
D2	Stand-by – board is OFF
D3	Power OK – +3.3V, +5V, +12V are present
D4	Power failure – one (or more) of the +3.3V, +5V or +12V power supplies failed
D5	Reset OK
D6	Host adapter link status: OFF – Link is not active ON – Link operates at 5.0 GT/s Blinking, 0.5 seconds ON, 0.5 seconds OFF – Link operates at 2.5 GT/s
D7	Host adapter link failure. When ON, Link is not active
D8	Transmitter fault indication. When ON, indicates a laser fault of some kind.
D9	Loss of Signal. When ON, indicates the received optical power is below the worst-case receiver sensitivity
D10	Factory use only
D11	Factory use only
D12	3.3V power OK

Designator	Description
D13	J1 slot: OFF – Link is disabled ON – Link is enabled, 5.0 GT/s Blinking, 0.5 seconds ON, 0.5 seconds OFF – Link is enabled, 2.5 GT/s
D14	J2 slot: OFF – Link is disabled ON – Link is enabled, 5.0 GT/s Blinking, 0.5 seconds ON, 0.5 seconds OFF – Link is enabled, 2.5 GT/s
D15	J3 slot: OFF – Link is disabled ON – Link is enabled, 5.0 GT/s Blinking, 0.5 seconds ON, 0.5 seconds OFF – Link is enabled, 2.5 GT/s
D16	J4 slot: OFF – Link is disabled ON – Link is enabled, 5.0 GT/s Blinking, 0.5 seconds ON, 0.5 seconds OFF – Link is enabled, 2.5 GT/s
D17	1V power OK
D18	Fatal error. When ON, fatal error is detected and a reset of the board may be required to return to reliable operation

4.3.4 Connectors and jumpers description

Table 4-10 Adnaco-R1BP1B Connectors

Designator	Description
J1	PCI Express x16 Add-in Card Connector (wired x1)
J2	PCI Express x16 Add-in Card Connector (wired x1)
J3	PCI Express x16 Add-in Card Connector (wired x1)
J4	PCI Express x16 Add-in Card Connector (wired x1)
J5	Main Power Connector (ATX24)
J6	Front Panel Header
J7	Chassis Fan Header
J8	Chassis Fan Header
J9	Standby 3.3V voltage 2-3 – default setting for a computer power supply. 1-2 – used for a custom power supply (there is no standby mode)
J10	Factory Only
J11	Not assembled
J12	+3.3Vaux source for PCI/PCIe slots Open – default, no +3.3Vaux voltage on the slots 1-2 – 3.3V main voltage from J5 connector 2-3 – 3.3V standby voltage from the local power supply (All add-in cards must consume less than 150 mA from +3.3Vaux power supply) Note: Although +3.3Vaux voltage is optional according to specifications some cards may not operate without it. It is left open by default

Table 4-11 J5 Main Power Connector

Pin	Signal Name	Pin	Signal Name
1	+3.3VDC	13	+3.3VDC
2	+3.3VDC	14	-12VDC
3	GND	15	GND
4	+5VDC	16	PS_ON#
5	GND	17	GND
6	+5VDC	18	GND
7	GND	19	GND
8	PWR_OK	20	Not Connected
9	+5VSB	21	+5VDC
10	+12VDC	22	+5VDC
11	+12VDC	23	+5VDC
12	+3.3VDC	24	GND

Table 4-12 J6 Front Panel Header

Pin	Signal Name
1	Reset Switch
2	Reset Switch
3	Power LED (-)
4	Not Connected
5	Power LED (+)
6	Stand-by LED (-)
7	Stand-by LED (+)
8	Power Switch
9	Power Switch
10	Not Connected
11	GND
12	Power Supply ON (jumper on pins 11-12) Leave open and use S1 DIP switch to control power supply during normal operation

4.4 Optical transceivers and fiber optic cable

The Adnaco systems can operate with multi-mode or single mode LC-LC fiber optic cable and transceivers. The cable type should match the optical transceivers type used in the system. Multi-mode transceivers and cable are intended for applications where required cable length is less than 250 m. Multi-mode transceivers are usually available in commercial 0° C to +70° C or extended -20° C to +85° C temperature range. Multi-mode transceivers are significantly less expensive compared to single-mode transceivers. The single-mode transceivers and cable can usually operate at longer distances and a wider temperature range. Single mode transceivers can also be used for applications where the remote backplane has to operate in the industrial temperature range from -40° C to +85° C.

4.5 ATX I/O shield

Figure 4-1 ATX I/O Shield



4.6 Adnaco-S1A system

[Click here to download latest S1A datasheet](#)

4.6.1 Block diagram

Figure 4-2 S1A system block diagram

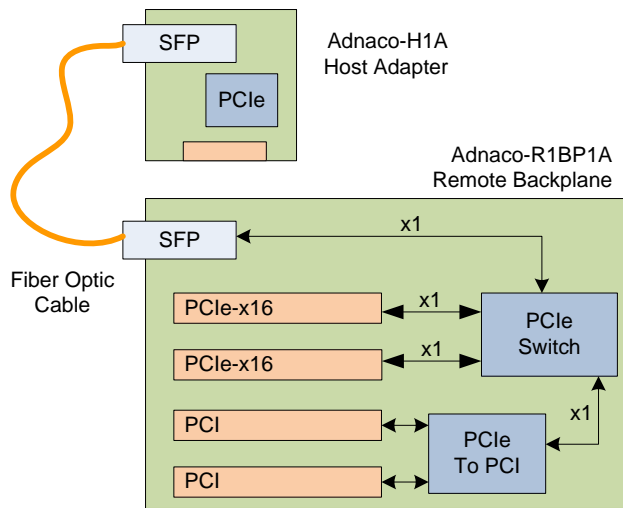

4.7 Adnaco-S1B system

[Click here to download latest S1B datasheet](#)

4.7.1 Block diagram

Figure 4-3 S1B system block diagram

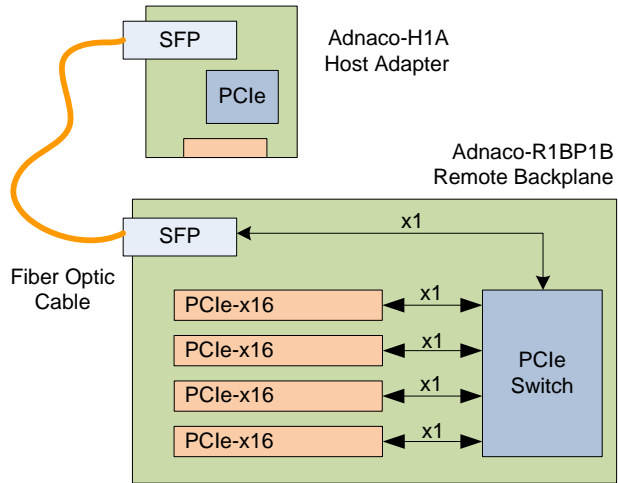

4.8 Adnaco-S2A system

Adnaco-S2A is Adnaco-S1A in a standard ATX case

[Click here to download latest S2A datasheet](#)

4.9 Adnaco-S2B system

Adnaco-S2B is Adnaco-S1B in a standard ATX case

[Click here to download latest S2B datasheet](#)

4.10 Ordering and pricing information

[Click here to download latest price list and ordering guide](#)

5 Installing Adnaco-R1BP1x in ATX chassis

5.1 Connectors schematic

Figure 5-1 R1BP1x connectors configurations

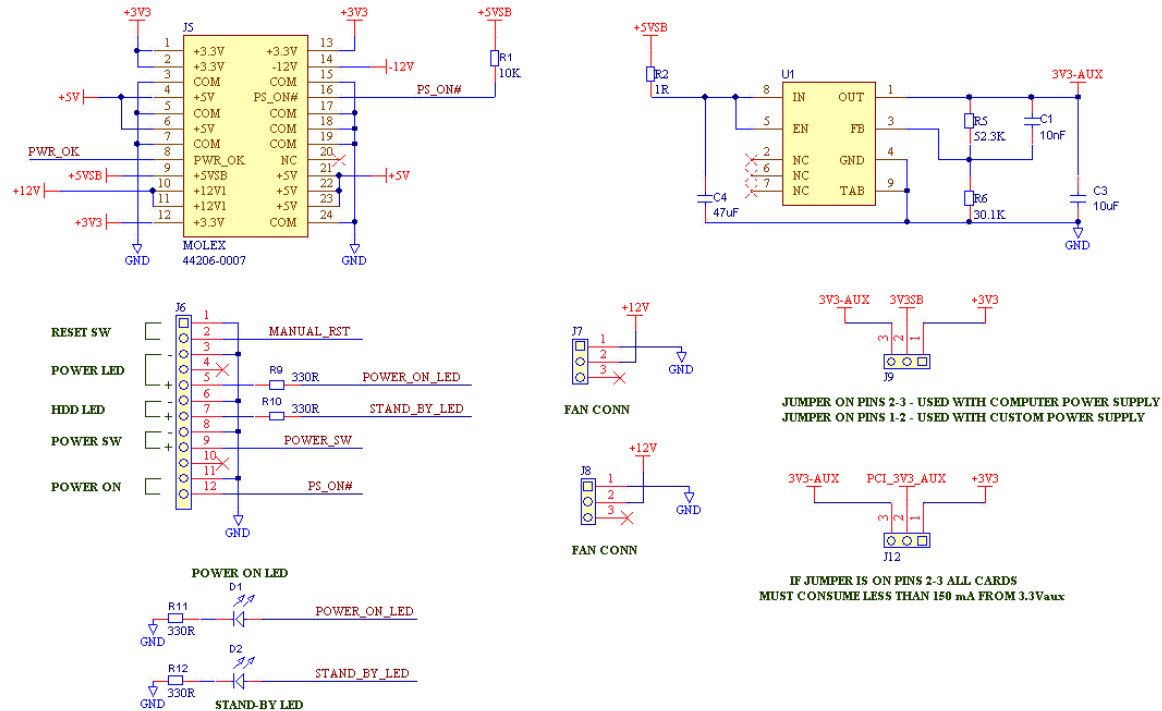

5.2 Power supply minimum load

The R1BP1x backplane is designed to be powered by a standard computer power supply. Many computer power supplies will require a minimum load in order to provide a stable output voltage and may not even turn on. If installed add-in cards do not consume enough power for stable power supply operation an additional load can be added by connecting chassis fans or a load resistor to the J7 and J8 connectors on the R1BP1x board.

5.3 Installing R1BP1x

- Unplug the power supply cord.
- Remove the chassis cover.
- Position the I/O shield inside the hole in the back of the computer chassis so that one side of the shield is under the retaining tabs on one side of the hole. Push the I/O shield forward until the other side of the shield snaps under the other set of retaining tabs.
- Before installing the R1BP1x remove the SFP optical transceiver.
- Refer to your chassis manual for instructions on installing and removing the computer motherboard and follow them to install the R1BP1x.
- Insert the SFP optical transceiver back into the cage until you feel the connector on the module snap into place in the back of the slot.

- Set the S1 DIP switch to the required power control configuration (see [7.1 R1BP1x Power On/Off Modes](#) for details)
- The [Table 5-1](#) below shows the pin assignment for the J6 front panel connector

Table 5-1 J6 Front Panel Header

Pin	Description	Wire name
1	Reset switch	RESET SW
2	Reset switch	RESET SW
3	Power ON green LED	POWER LED (-)
4	Not Connected	
5	Power ON green LED	POWER LED (+)
6	Stand-by yellow LED	HDD LED (-)
7	Stand-by yellow LED	HDD LED (+)
8	Power On/Off Switch	POWER SW
9	Power On/Off Switch	POWER SW
10	Not Connected	
11	Not Connected	
12	Not Connected	

- Connect the main power supply cable (20 or 24 pin connector) to the R1BP1x J5 connector.
- Install your add-in cards. Follow the recommendations and procedures provided by the card manufacturer for installation into standard computer slots.
- Install the chassis cover.

6 Using R1BP1x with Custom Power Supply

6.1 Custom power supply requirements

Although the R1BP1x is designed to operate with a standard computer power supply some applications may require using a custom power supply.

The R1BP1x requires a 3.3V power supply with 2 A maximum current. The add-in cards may require additional power so please check power requirements for your add-in cards and add them to your power supply specifications. PCIe cards may require +12V. The PCI cards may require some of the following voltages: +5V, +12V, -12V.

We cannot guaranty that the R1BP1x will work with any custom power supply unless the power supply meets the [Power Supply Design Guide for Desktop Platforms](#). The main requirements are shown below.

The DC output voltages must remain within the regulation ranges shown in [Table 6-1](#) when measured at the J5 connector on the R1BP1x board under all line, load, and environmental conditions.

There is no specific requirement for power supply sequencing of each of the power supply outputs. They may come up or go down in any order. If an add-in card requires power supply sequencing, it is the responsibility of the add-in card designer to provide appropriate circuitry on the add-in card to meet any power supply sequencing requirements.

Table 6-1 DC Output Voltage Regulation

Output	Range	Min	Nom	Max	Unit
+12V1DC ¹	±5%	+11.40	+12.00	+12.60	V
+12V2DC ²	±5%	+11.40	+12.00	+12.60	V
+5VDC	±5%	+4.75	+5.00	+5.25	V
+3.3VDC ³	±5%	+3.14	+3.30	+3.47	V
-12VDC	±10%	-10.80	-12.00	-13.20	V
+5VSB	±5%	+4.75	+5.00	+5.25	V

Table 6-2 Output Transient Response

Output	Maximum Step Size (% of rated output amps)	Maximum Step Size (A)
+12V1DC	40%	-
+12V2DC	60%	-
+5 VDC	30%	-
+3.3 VDC	30%	-
-12 VDC	-	0.1
+5 VSB	-	0.5

Table 6-3DC Output Noise/Ripple

Output	Maximum Ripple and Noise (mV p-p)
+12 V1DC	120
+12 V2DC	120
+5 VDC	50
+3.3 VDC	50
-12 VDC	120
+5 VSB	50

The power on/off switch used in the system with a custom power supply should be connected to the input of the power supply or to a power control signal similar to the PS_ON# signal in the computer power supply. Using a power switch between the power supply outputs and the R1BP1x board is not allowed and may result in voltage overshoot and damaging the R1BP1x and installed add-in cards.



Warning: The connection between the power supply and the R1BP1x board must not be interrupted when the power supply is ON or its bypass capacitors are not fully discharged.

6.2 Power cable

For power supply connection we recommend using an ATX power extension cable available in computer stores. Use a 24 or 20 pin connector.

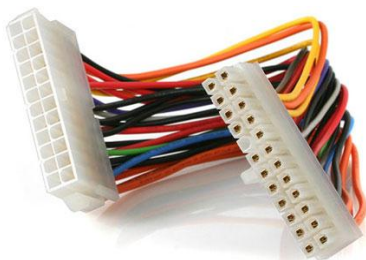
Figure 6-1 ATX power extension cable

Cut one connector and use wires to make a power cable for your power supply. Make appropriate connection using the connector pin-out shown below. Connect only signals which are used. Do not connect the PS_ON#, PWR_OK and +5VSB unless they are implemented in your power supply.

Figure 6-2 Cable Main Power Connector (Pin-side view)

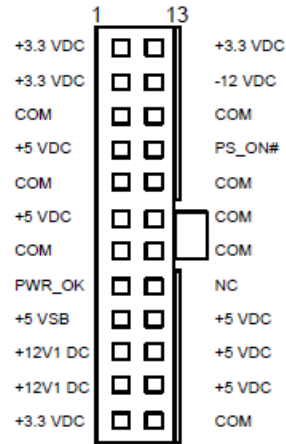

Figure 6-3 R1BP1x Main Power Schematic

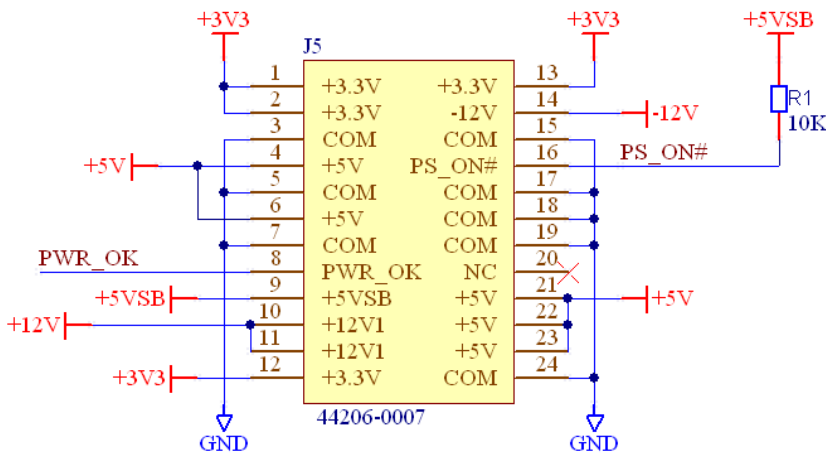

Table 6-4 Main Power Connector Pin-out

Pin	Signal	Color	Pin	Signal	Color
1	+3.3VDC	Orange	13	+3.3VDC	Orange
2	+3.3VDC	Orange	14	-12VDC	Blue
3	GND	Black	15	GND	Black
4	+5VDC	Red	16	PS_ON#	Green
5	GND	Black	17	GND	Black
6	+5VDC	Red	18	GND	Black

Pin	Signal	Color	Pin	Signal	Color
7	GND	Black	19	GND	Black
8	PWR_OK	Gray	20	Reserved	-
9	+5VSB	Purple	21	+5VDC	Red
10	+12VDC	Yellow	22	+5VDC	Red
11	+12VDC	Yellow	23	+5VDC	Red
12	+3.3VDC	Orange	24	GND	Black

6.3 R1BP1x configuration

- Set jumper on pins 1-2 of J9 connector on the R1BP1x. The R1BP1x cannot control a custom power supply and therefore the local standby voltage is not required.
- Set S1.5 DIP switch to the ON position to set the R1BP1x in the always ON mode. If your power supply has PS_ON# and +5V standby voltage then you can use any power control mode described in [7.1 R1BP1x Power On/Off Modes](#)
- Connect a Power ON indicator LED to the pins 3 and 5 on the J6 connector (see [Figure 6-4](#) Figure 6-4 J6 Front Panel Header)
- Connect a Reset Switch to the pins 1 and 2 on the J6 connector (see [Figure 6-4](#))

Figure 6-4 J6 Front Panel Header

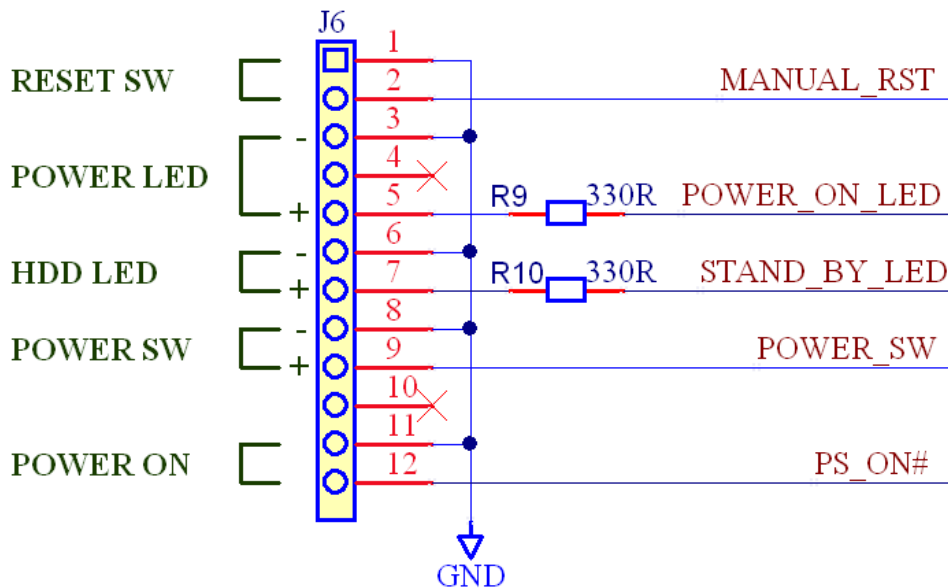

6.4 Connecting power supply to R1BP1x

Before connecting your power supply to the R1BP1x turn it on and, using a multi-meter, measure all voltages on the pins of the power connector and make sure that they are within the specifications shown in [Table 6-1](#). Then turn the power supply off and wait until all bypass capacitors in the power supply are discharge. Without a load it may take some time until capacitors

are fully discharged so verify with a multi-meter that all voltages on the connector pins are 0V. Connecting power cable when the power supply is on or its bypass capacitors are not fully discharged may result in damaging the R1BP1x and installed add-in cards.

7 System Operation

7.1 R1BP1x Power On/Off Modes

The R1BP1x has a control signal which can turn on and off a standard computer power supply. The R1BP1x can operate in one of 3 power control modes.

Table 7-1 R1BP1x Power Control Modes

Mode	R1BP1x S1 switch	Description
1	S1.4 = OFF, S1.5 = OFF	Power On and Off is controlled by the momentary button SW1 or an external momentary switch connected to the J6 pins 8 and 9
2	S1.4 = ON, S1.5 = OFF	Power supply and the R1BP1x are always On This mode should be used with a custom power supply
3	S1.4 = OFF, S1.5 = ON	Power is turned On and Off automatically when the computer is turned On and Off

Note: Disconnection of the Fiber Optic Link with the System powered on will require a Power-Off/On sequence to resume operation.

7.2 Manual Power-On/Off Sequence (modes 1 and 2)

Power-On Sequence

- Power on the Adnaco-R1BP1x.
- Power on the host computer.

Power-On Sequence Rationale: The host computer BIOS and OS assume all PCI/PCIe cards are available for first code execution following power-up.

Power-Off Sequence

- Power off the host computer.
- Power off the Adnaco-R1BP1x.

Power-Off Sequence Rationale: OS and Drivers assume all PCI/PCIe cards are always available from power-on to power-off.

7.3 Automatic Power-On/Off Sequence (mode 3)

Mode 3 can be used only with a standard computer power supply or a power supply with a PS_ON# signal compliant with the [Power Supply Design Guide for Desktop Platforms](#). After installing the system connect the power cord and switch ON the power switch on the R1BP1x power supply in order to provide standby power to the R1BP1x. In this mode power sequence is controlled automatically. When the computer is turned ON and OFF the R1BP1x is turned ON and OFF automatically.

8 System Installation

8.1 Installation recommendations

It is highly recommended to update the computer BIOS and OS. If the BIOS is more than 1-2 years old it may not allocate PCI resources for multiple PCI-PCI bridges and the extension will not operate properly. A number of system vendors have released updates that fix many issues related to the PCI Express expansion systems. The latest BIOS update and its installation instructions can be downloaded from the computer or motherboard manufacturer's web site. If after the BIOS is updated and the problem is not solved try a different computer. We recommend to use computers with 965, G33 or newer chipsets and Intel motherboards. Computers with 915, 945, 955 chipsets are not recommended due to problems with the BIOS.

If you experience any problems, please review [10 Troubleshooting](#)

	ESD Warning The electronic parts are sensitive to electrostatic discharges. Please use an electrostatic wrist strap and/or conductive mat when executing the steps below.
-----------------------------------------------------------------------------------	----------------------------------------------------------------------------------------------------------------------------------------------------------------------------------

8.2 Installing Adnaco-H1A PCIe Host Adapter Card

- Power off the host computer and unplug its power cord.
- Remove the computer's cover.
- Identify any PCIe x1, x2, x4, x8 or x16 slots on the motherboard.
- Remove the metal bracket (that covers the cut-out in the chassis back panel) for the slot you have selected. Keep both the bracket cover and retaining-screw.
- Insert the H1A card into the identified PCIe slot by gently pushing the card. Secure the card to the computer chassis using the retaining screw.

NOTE: The BIOS or motherboard may not support a PCIe host card in a slot intended for a graphics card (PCIe x16). For more information on installing PCIe cards please refer to your computer's user's manual.

8.3 Installing Third-Party PCI or PCIe Cards in the Adnaco-R1BP1x backplane

- Power off the R1BP1x and unplug power cord from its power supply.
- Wait until all LEDs on the R1BP1x are OFF.
- Follow the recommendations and procedures provided by the card manufacturer for installation into standard computer slots.

8.4 Connecting the Fiber Optic Cable

- Remove the plastic protection plugs from one end of the fiber optic cable and connect the cable to the H1A SFP transceiver.
- Remove the plastic protection plugs from the other end of the fiber optic cable and connect the cable to the R1BP1x SFP transceiver.

8.5 Turning on system for the first time

- Power on the system as indicated in [7 System Operation](#).
- The OS will install drivers for the H1A and R1BP1x boards if it is connected for the first time. The boards use standard PCIe switches and bridges and therefore all drivers are included in the OS.
- If the OS cannot install software driver(s) for newly added card(s) automatically then follow the card(s) software and drivers installation guides.
- You may need to reboot the host computer after driver installation is completed.
- If there are several different cards installed into the R1BP1x to the host computer you may need to reboot a few times until the OS can install all drivers successfully.
- You can verify the installation was successful by checking in the Device Manager as indicated in [9 Verifying System Functionality](#).
- Once installation is completed your card(s) is(are) ready to operate remotely from the host computer at a distance up to the maximum length of the fiber optic cable.

9 Verifying System Functionality

To verify a successful installation, use the **Device Manager**. In the **Device Manager** click on the **View** Menu and select **View Devices by Connection**.

Figure 9-1 Device Manager

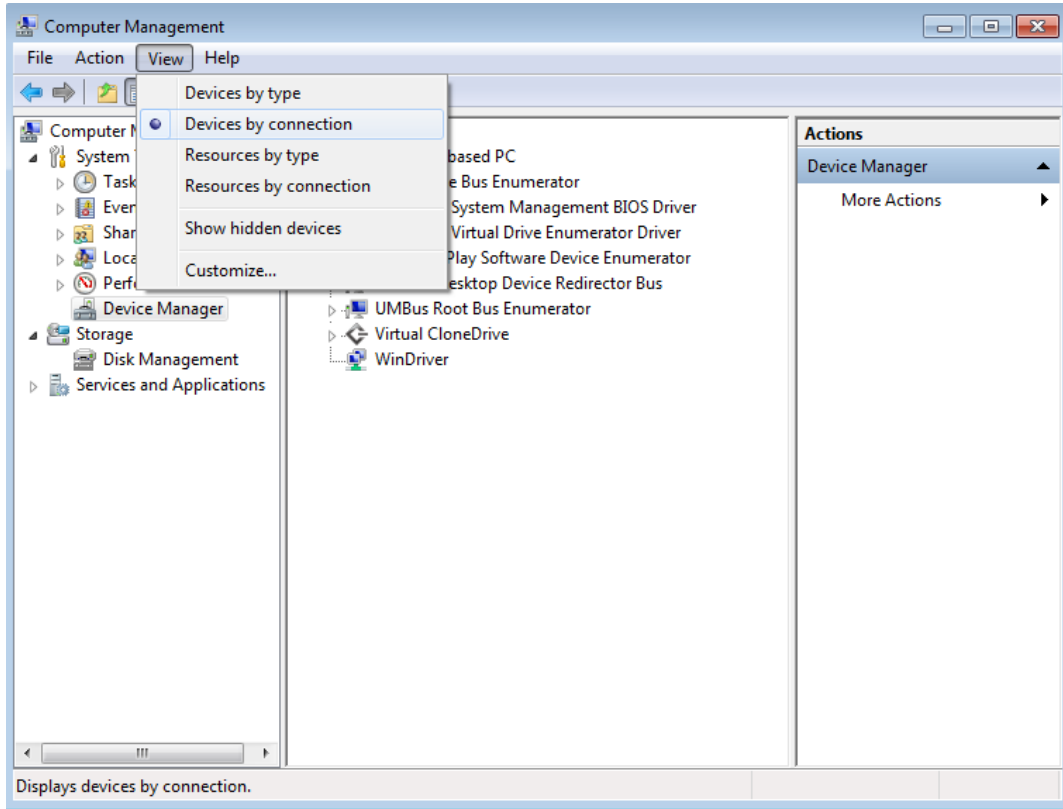

To see if your installation is successful click on the sign to the left of the **ACPI** to open it, then within **PCI Bus** check the lines containing the words "**PCI Express Root**" or "**PCI standard PCI-to-PCI bridge**". Under one of the lines you should see multiple PCI-to-PCI bridges and your add-in cards. The [Figure 9-2](#) below shows the H1A and R1BP1A with two installed PCIUSB host controller cards.

Figure 9-2 S1A System View in Device Manager

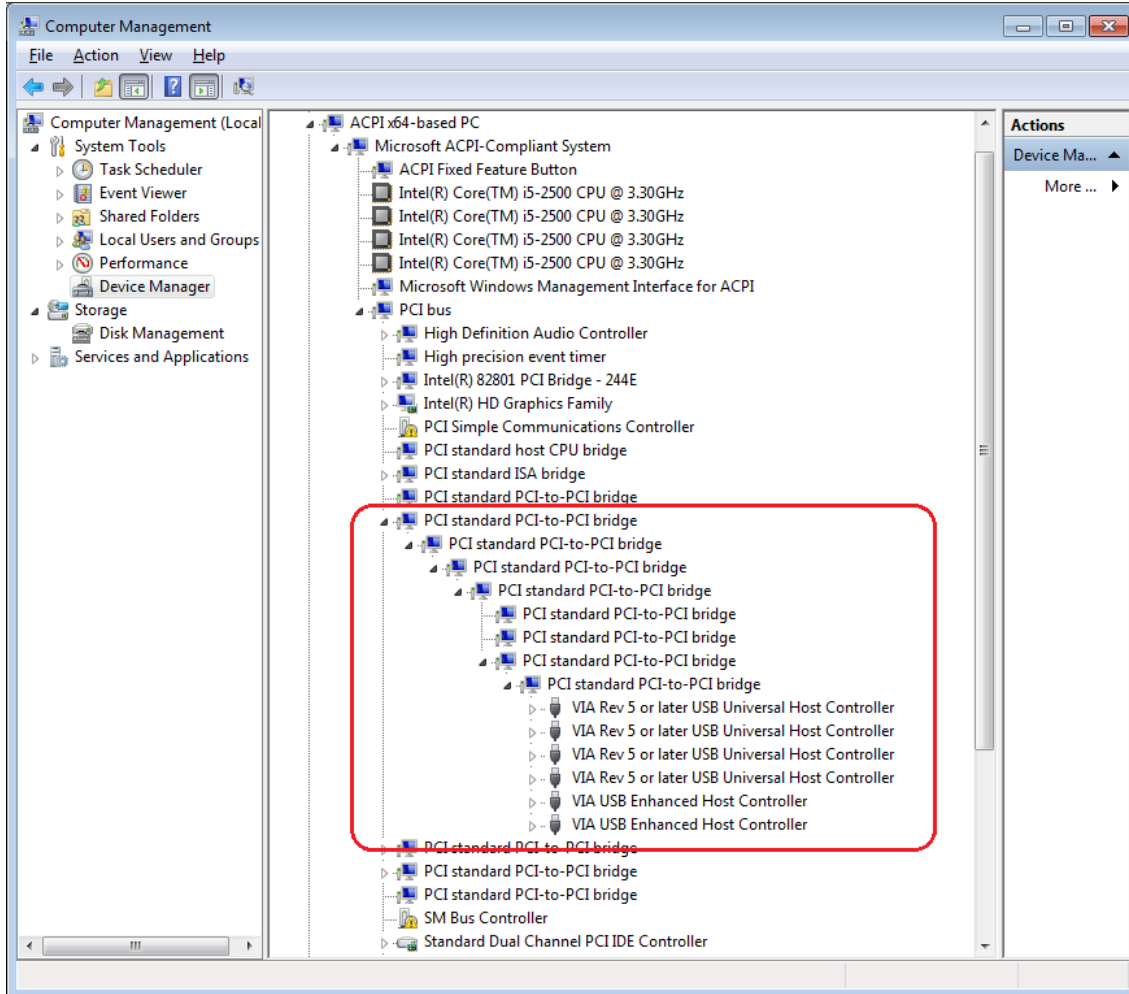

Right-click on the “**PCI standard PCI-to-PCI bridge**” line you want to view, then click **Properties**. On the **Details** tab you can verify a vendor and the device id of the selected device.

All boards have the **Vendor ID =10B5** and **Device ID=8608**. The device and subsystem IDs are shown below

Figure 9-3 H1A Device ID=8608, Subsystem Vendor ID = AAAA and Subsystem ID = 0081

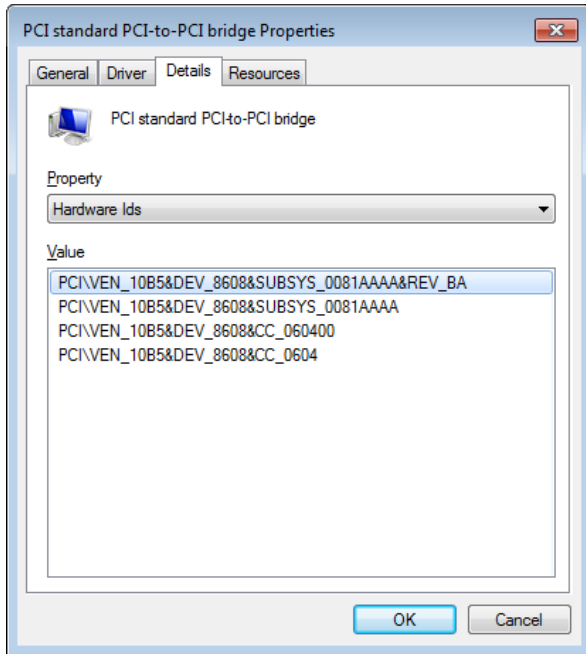

Figure 9-4 R1BP1A Device ID=8604, Subsystem Vendor ID = AAAA and Subsystem ID = 0042

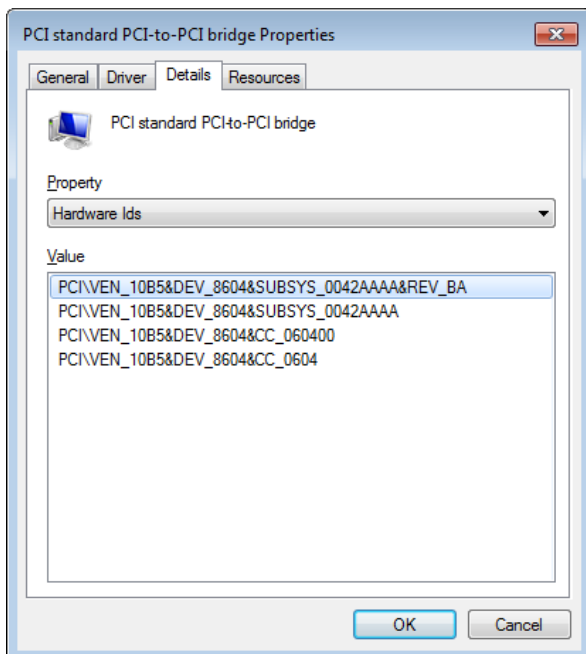
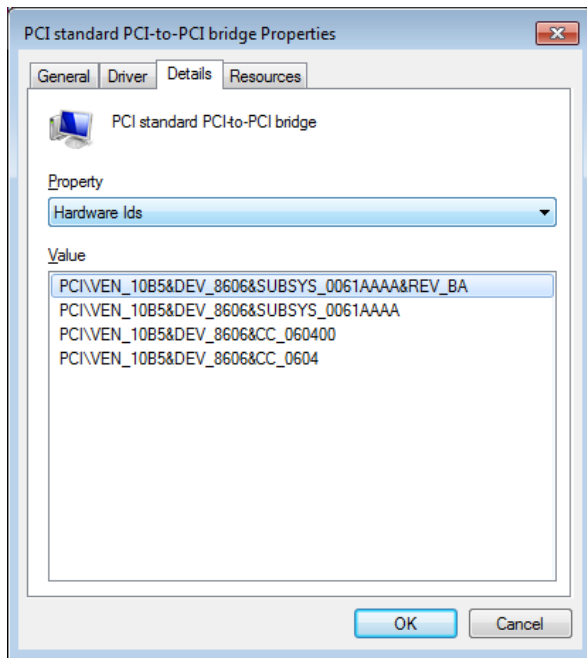

Figure 9-5 R1BP1BDevice ID=8606, Subsystem Vendor ID = AAAA and Subsystem ID = 0061

Note: Sometimes, if there are several devices connected to the host computer you may need to reboot the computer two or three times. It is actually preferred to sequentially add devices to the host computer – first the H1A, then the R1BP1x, and then insert new cards into the R1BP1x.

If the installation was unsuccessful, please go to [10 Troubleshooting](#)

10 Troubleshooting

Following all the steps detailed in the previous sections will guarantee a successful operation of the system in most cases. However, if you are facing any problems, please read the cases below which address possible problems that could prevent you from running your system successfully.

Most problems can be identified by checking the LED statuses.

Table 10-1 LEDs description

Board	LEDs status description
H1A	4.1.3 LEDs description
R1BP1A	4.2.3 LEDs description
R1BP1B	4.3.3 LEDs description

10.1 The R1BP1x is not turning ON or its LEDs (other than link LEDs) are flashing

Please read [8.1 Installation recommendations](#) regarding power supply minimum load requirements.

Note: When PCIe links operate in Gen1 mode the link LEDs are blinking 0.5 seconds ON, 0.5 seconds OFF and this indicates normal board operation.

10.2 Your host computer BIOS is not up-to-date

In order to update your BIOS please do the following:

- Power off the system.
- Remove the H1A from the host computer.
- The BIOS update is normally obtained from the maker of the computer, or in the case of a non-brand computer, from the maker of the motherboard or sometimes the BIOS maker itself.
- Repeat [8 System Installation](#).

You may still face the following problems after updating the BIOS:

10.3 The H1A is not visible in the Device Manager

- Make sure the S1.4 switch is in the OFF position, see [4.1.2 H1A DIP switch description](#) for details.
- Check to assure the H1A is properly installed. Please refer to your computer or motherboard user's manual for information on how to install PCI Express add-in cards.
- Check the D3 LED host PC link status. If the link is disabled verify that the PCIe slot is operational by inserting a different PCIe card in the slot.
- Try installing the H1A in another computer (if available) to see if that fixes the problem. This may rule out a defective H1A card.
- If the problem is not solved please go to [12 Customer Support](#).

10.4 The host computer hangs during power on

- Power off the system as indicated in [7 System Operation](#).
- Disconnect the fiber optic cable from the R1BP1x.
- Power On the host computer and check whether this solves the problem or not.

- If the problem is not solved please try a different computer (if available).

10.5 Fiber optic cable and transceivers verification

The status of PCIe links LEDs is correct when computer is initialized PCI/PCIe bus hierarchy, otherwise they can show status of not initialized PCI/PCIe local links.

- Power on the system as described in [7 System Operation](#).
- When the cable and transceivers operate properly the green LED D4 on the H1A and the D6 one on the R1BP1x indicate that link is enabled and its speed. When link is not established the red LED D5 on the H1A and the D7 one on the R1BP1x are ON.
- If there are some problems with optical transceivers or fiber optic cable the red D6 and D7 LEDs on the H1A and the D8 and D9 LEDs on the R1BP1x are ON. Try to remove and reinstall optical transceivers and reconnect the fiber optic cable. If at least one of the red LEDs is still ON try a different fiber optic cable (if available).
- Verify the H1A and R1BP1x use the same frequency settings (S1.3 DIP switch).
- **If on the R1BP1x the D3 or D5 LEDs are OFF and/or the D4 is ON then this may indicate some problems with the power supply.** Please read [8.1 Installation recommendations](#) regarding power supply minimum load requirements and if it doesn't solve the problem replace the power supply.
- If the problem is not solved please go to [12 Customer Support](#).

10.6 The R1BP1x is not visible in the Device Manager

- Power off the system as described in [7 System Operation](#).
- Remove all add-in cards from the R1BP1x.
- Power on the system as described in [7 System Operation](#)
- If the R1BP1x is visible in the Device Manager then the problem is with the add-in card(s) installation, go to [10.7 Third-party add-in cards installation problem](#).
- If the R1BP1x is not visible in the Device Manager, and you tried all previous steps above, please go to [12 Customer Support](#).

10.7 Third-party add-in cards installation problem

You can install your add-in card(s) in the host computer to verify that the card(s) hardware and drivers operate properly. If you experience difficulties installing your third party cards, the card manufacturer or your OS vendor may be able to provide the best support. Please read [11 Adnaco Products Design Disclaimer](#)

10.7.1 Add-in card requires auxiliary voltage to operate

Although a 3.3V auxiliary voltage is optional according to the PCI and PCIe specifications some cards may not operate without it. If the card doesn't work without the auxiliary voltage then install a jumper on the J12 connector – see [4.2.4 R1BP1A](#) and [4.3.4 R1BP1B](#) jumper's description

10.7.2 PCIe add-in card problems

- Verify that the PCIe slots are functional by checking the LED status for each slot. If LEDs are blinking or ON then the hardware is functional and you need to verify the driver installation [9 Verifying System Functionality](#).
- If the LEDs are off, then no PCIe link is established and the problem is with the hardware. First, try to insert the card in a different slot on the R1BP1x, and then try a different tested PCIe card.

If the card is a PCIe Gen 1 then check [10.7.3 Interoperability issues with some PCIe Gen 1 cards](#). If there is still no link with another card and it is known that the card is good and works in a computer slot please go to [12 Customer Support](#).

10.7.3 Interoperability issues with some PCIe Gen 1 cards

Some PCIe Gen1 cards are not fully compliant with PCIe Gen 2 specification and as a result they cannot link with the Gen2 switch used in the R1BP1x. For such cards the recommended workaround is to set the PCIe operating mode to the Gen1 mode by setting the S1.1 DIP switch on the R1BP1x to ON position. If after setting that mode there is still no link and it is known that the card is good and works in a computer slot then please go to [12 Customer Support](#).

10.7.4 PCI add-in card problems

- Check that the PCI bridge link LED D15 on the R1BP1A is blinking. If it is OFF please go to [12 Customer Support](#).
- Replace your add-in card with a tested PCI card and verify the system functionality. If the verification fails please go to [12 Customer Support](#).

11 Adnaco Products Design Disclaimer

The Adnaco Technology products are designed according to PCI specifications listed in their data sheets. Hence, they should work with all add-in cards and drivers compliant with those PCI specifications. Adnaco Technology can only provide limited support with third-party add-in cards installations. Please go to [12 Customer Support](#) to contact our Support Team.

12 Customer Support

For the latest Customer Support information please visit our website at www.adnaco.com. When contacting us, please make sure to include all the information below and describe your problem in detail to help us understand your problem better.

- 1) Full Name.
- 2) Company Name.
- 3) Phone Number.
- 4) Fax Number.
- 5) Email Address.
- 6) Product Model Number.
- 7) Product Serial Number.
- 8) Computer Make.
- 9) Computer Model.
- 10) OS and Version.
- 11) Make/Model of PCI cards installed.
- 12) LEDs status on all boards
- 13) Detailed description of the problem.

13 Warranty

All items of the Adnaco system components are warranted against defects in materials and workmanship for a period of one year from the date of shipment. Adnaco Technology will repair or replace (at its option), at no charge, any item(s) found to be defective during the warranty period. This warranty includes parts and labor. Proof of purchase is required for any warranty work. The warranty provided herein does not cover defective items caused by owner's failure to follow this User's Guide; owner's modification of the product; owner's abuse, misuse, or negligent acts; and power failure or surges, fire, flood, accident, actions of third parties, or other events outside reasonable control. In order to return defective items, an RMA number must be obtained from Adnaco and clearly marked on the outside of the package before any item(s) will be accepted for warranty work. The returned item(s) must be packaged in a manner similar to the manner it (they) was(were) received. Failure to do so will void the warranty. After obtaining the RMA number and properly packaging the defective item(s) please ship the package to the address indicated at our website www.adnaco.com. Please make sure the package label clearly indicates the RMA number provided.

EXCEPT AS SPECIFIED ABOVE, ADNACO TECHNOLOGY INC. MAKES NO WARRANTIES, EXPRESS OR IMPLIED, AND SPECIFICALLY DISCLAIMS ANY WARRANTY OF MERCHANTABILITY OR FITNESS FOR A PARTICULAR PURPOSE. CUSTOMER'S RIGHT TO RECOVER DAMAGES CAUSED BY FAULT OR NEGLIGENCE ON THE PART OF ADNACO TECHNOLOGY IS LIMITED TO THE AMOUNT PAID BY THE CUSTOMER. ADNACO TECHNOLOGY IS NOT LIABLE FOR DAMAGES RESULTING FROM LOSS OF DATA, PROFITS, USE OF PRODUCTS, OR INCIDENTAL OR CONSEQUENTIAL DAMAGES, EVEN IF ADVISED OF THE POSSIBILITY THEREOF.

14 Appendix A Board drawings with dimensions

[Click here to download R1BP1A drawing](#)

[Click here to download R1BP1B drawing](#)